

## Automatic meter reading system gives Bill Gates peace of mind

When Bill Gates began building his new home on Lake Washington near Seattle, expectations for the dream house ran high. After seven years of construction, the 45,000-sq-ft residence has been appraised at more than \$53 million. Not surprisingly, the typical monthly electric bill is also expensive — it averages \$30,000.

Because of this expense, Gates needed a way to monitor and track his electrical use down to the subpanel level. Now, thanks to the recent installation of a full-featured automatic meter reading (AMR) hardware and software system (E-MON Corp., Langhorne, Pa.), Gates knows exactly what the electrons he buys are doing — anytime, day or night.

As one might expect from the co-founder of Microsoft®, Gates built a compound full of futuristic electronic gadgetry. Visitors wear small electronic pins coded with their preferences for room temperature, visual art, music, television programs, and movies. Computers track the pins as visitors travel from room to room.

All floors, driveways, and walkways at the Gates residence are heated, and a 10-car subterranean garage electronically transforms into a basketball court. Automated security systems and hidden cameras cover every inch of the grounds, and floor sensors track visitors to within six inches of their location.

More than 100 electricians were involved in the installation of these systems. Many miles of communication cable — mostly fiber optics — connect computer servers throughout the house, yet no electrical outlets are visible.

Operating and maintaining these electrical systems is a huge job, but the AMR system helps by providing current usage data. The system hardware in Gates' basement consists of a multiple meter unit housing eight submeters and a single computer interface module. The module digitizes the submetered electrical readings for use by Windows®-compatible software.

The 480-v electrical service consists of multiple 200-, 400-, and 800-amp loads. The software is capable of displaying submetered data gathered in five-, 15-, 30-, or 60-min intervals. It can then profile the information in a number of useful ways from a centralized PC. The software can export data files to any spreadsheet program for a statistical analysis of energy consumption for peak shaving, load shedding, or negotiating lower power rates. The system is also scalable, accepting an unlimited number of meters should Gates expand his system to accept inputs from water, gas, BTU, or other pulse-output meters.

Whether or not Gates will expand his system is anyone's guess. But one fact is clear: Industrial and commercial facilities benefit just as much as Gates does from monitoring electrical use patterns. Information from electric meters can be used to implement demand reduction programs in facilities and save thousands of dollars on electric bills. You don't have to be Bill Gates to appreciate that kind of savings (and your facility probably needs that extra money more than he does).

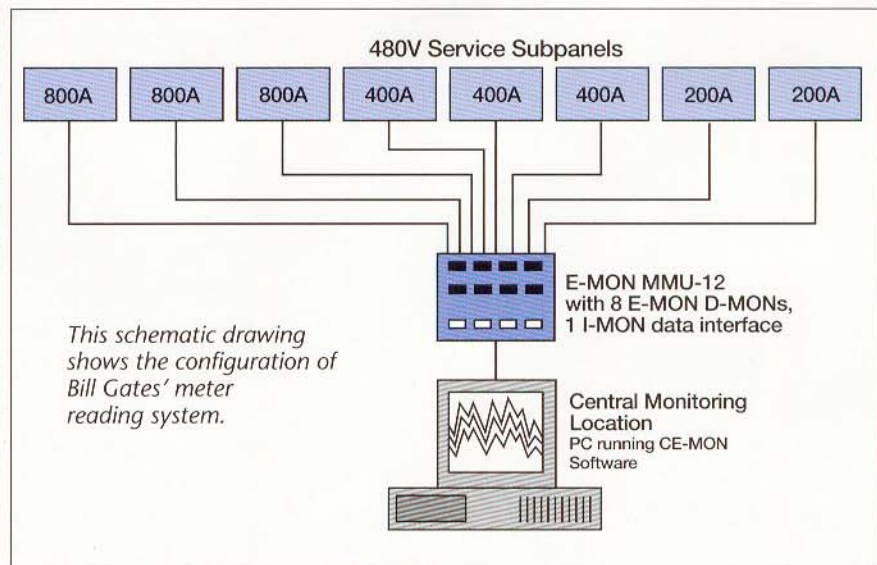

For more information please contact E-Mon Corp.  
800-334-3666 [www.emon.com](http://www.emon.com) E-Mail: [info@emon.com](mailto:info@emon.com)