

E-Mon D-Mon[®] Installation Manual

Class 3000
KWH/Demand Meter
with Communications



Dear Valued Customer,

We are pleased that you chose to buy one of our products, and want you to be just as pleased with owning it. Before installing your new E-Mon product, please read the information on the following pages carefully.

We believe that you will find the E-Mon D-Mon meters easy to install and to use for monitoring and evaluating your electrical usage.

To be sure that you are 100% satisfied with your products, we provide toll-free technical and sales support Monday through Friday, 8:00 am to 7:30 pm, EST: (800) 334-3666. You may also reach us via email at info@emon.com.

If you have questions, we can handle them quickly and effectively with a telephone call. Please let us try to help you BEFORE you remove your meter. And to help us help you, we ask that you have all relevant information on hand when you call (model or part numbers, nature of difficulty, etc.)

Be sure to forward this manual to the owner after installation is complete, so that they may use it as a reference guide when reading the E-Mon D-Mon meter.

Thank you.

Table Of Contents

		Page
Section 1.0	Introduction	1
Section 1.1	Internal Electronic Assemblies	2
Section 2.0	Meter Technical Specifications	4
Section 3.0	Safety Label Definitions	5
Section 4.0	Precautionary and Safety Information	5
Section 5.0	Meter Installation	6
Section 5.1	Mounting the Class 3000 Meter	6
Section 5.2	Main Power Board Connections	6
Section 5.3	Phasing of Line Voltage	8
Section 5.4	Current Sensor Installation & Wiring	8
Section 5.5	Main Power & Current Sensor Wiring Diagrams	11
Section 5.6	Line Voltage/Sensor Diagnostics	12
Section 5.7	RS-485 Communications	14
Section 5.8	RS-232 Communications	15
Section 5.9	Modem Wiring	18
Section 5.10	Modbus Wiring	20
Section 5.11	Ethernet Communications	20
Section 6.0	Multiple-Load Monitoring	21
Section 7.0	Preventative/Scheduled Maintenance	22
Section 8.0	Lithium Battery Replacement	22
Section 9.0	Class 3000 Features	24
Section 10.0	Reading The Class 3000 Meter	26
Section 11.0	Frequently Asked Questions	27
Section 10.0	Meter Limited Warranty	28

1.0 Introduction

The E-Mon D-Mon® Class 3000 meter is a 3-element meter with communications. The device is used to monitor electric power usage of individual loads after the utility meter and store kW and kVAR data for automatic meter reading. Installation must only be performed by qualified personnel and in accordance with these instructions and all applicable local and national electrical codes. E-Mon and its representatives assume no responsibility for damages or injury resulting from the improper installation of this meter.

Verify the input voltage rating and configuration on the unit panel label to ensure that it is suitable for the intended electrical service. Class 3000 meters labeled for 120/208V service **MUST NOT** be installed on service feeds of 277/480 volts, and vice versa.

Verify that the Class 3000 meter's current sensors are sized suitably for the load to be monitored. Compare the color of the arrows on the current sensors to the chart below to confirm the correct current sensor is being used.

Sensor Arrow Color code	Sensor Rating (Amps)
Brown	100 A
Red	200 A
Yellow	400 A
Black	800 A
Blue	1600 A
White/Black	3200 A

Table 1.0.1. Sensor arrow color codes.

CAUTION: Internal circuit components are extremely sensitive to electrostatic discharge. Prior to handling or touching internal circuitry, discharge any static buildup on your person. To discharge yourself, touch a grounded metal object such as conduit or an earth-grounded metal enclosure.

WARNING: Use of this instrument, the E-Mon D-Mon Class 3000 meter, in a manner inconsistent with this manual or not specified by the manufacturer in writing, can cause permanent damage to the unit and/or serious injury to the operator. The protection and safety features provided by this equipment may become impaired or otherwise compromised.

Note: If any trouble arises during the installation or functional verification operations, do not immediately remove the unit. Before removing the unit, contact E-Mon's technical support and/or engineering department at (800) 334-3666. E-Mon's technical department will assist you in detailed troubleshooting of the Class 3000 meter installation and assist you in getting the unit operating correctly.

1.1 Internal Electronic Assemblies

The unit is comprised of two major subassembly boards, the main power board and the display board. Both circuit cards are mounted inside a NEMA 12/13 enclosure.



Figure 1.1.1 Internal electronic assemblies.

1.1.1 Meter Board

Connections to this board include the MAINS input voltage, current sensors, and the control relay contacts (optional). The MAINS input terminals are covered with a protective clear shield for safety purposes. The current sensor assemblies interface to three header connectors, TB1, TB2 and TB3. Each header connector input corresponds to an input voltage phase; care must be exercised to ensure that each current sensor is connected to the correct input header.

External meter input TB4, at the top right of the main power board, is used for an external utility meter or submeter input being monitored by the Class 3000 meter. This data, accessed only through E-Mon's E-Mon Energy software, is not shown on the Class 3000 meter display.

Header connector TB5 provides contact closure information for the control relay. The relay contacts are rated for 28 Vdc @ 10A or 240 VAC @ 10A.

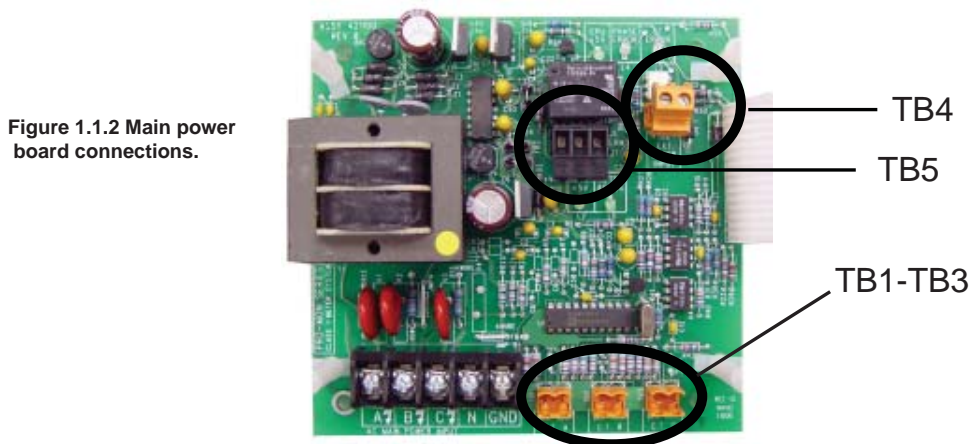

Figure 1.1.2 Main power board connections.

1.1.1 Meter Board (continued)

There are also 3 registers on the Class 3000 meter. Register 1 is for kWh, Register 2 is for kVARh and Register 3 contains the pulse data from external input TB4. This data is determined by the type of meter supplying the pulse (water, gas, etc.) Registers 1 & 2 are from the Class 3000 meter and are always functioning.

1.1.2 Display Board

The display board connects to the main power board via a flex ribbon cable and the board mounts on the inside of the housing door. The only required connection is for RS-485 communications. When operated as a stand-alone unit using a modem for communications, the RS-485 connections are not required. The display board's LCD readout indicates the metered values as well as errors associated with the Class 3000 meter, such as low battery or sensor error conditions.

2.0 Meter Technical Specifications

Ordering Information: Define input voltage, current sensor rating, system modem option and firmware, in the format XXX-YYYY-C-M-ZZZZ, where

XXX=input voltage (115, 208, 220, 277, 480)

YYY=current sensor rating (100, 200, 400, 800, 1600, 3200)

C = designates Class 3000 meter

M=modem option (omit if unnecessary)

ZZZ=Communication option (E=Ethernet, RTU=Modbus, LC=Load Control)

Example:

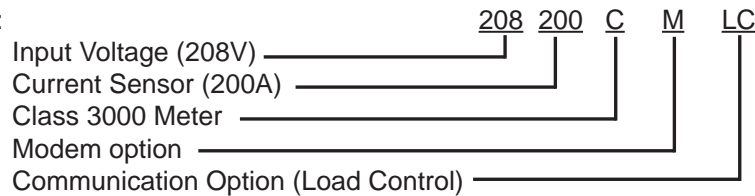

Input Voltage Configuration	3-Wire (delta) or 4-Wire (wye)
MAINS Voltage Input	Up to 480 VAC RMS Available
Input Power	12 VA maximum rating
Current Sensor Rating	Up to 3200 amps RMS AC available
Power Factor	0.5 leading or lagging
Line Frequency	50-60 Hz
Metering Accuracy	Certified to ANSI C12.16 (+/-1% from 1-100% of rated load)
Voltage Operating Range	+/-10% of rated load
Temperature Range	-20 degrees C to +50 degrees C
Relative Humidity Range	0-95% non-condensing
Altitude	2000 meters maximum
Voltage Overload	+25% continuously; +100% for 20 cycles
Current Sensor Overload	100% for 1 minute without damaging meter
Pollution Degree	Degree 2 in accordance with IEC 664
Installation (Overvoltage) Category	Category III
Measurement Category	Category III
Enclosure Material	NEMA 12/13
Display Readout	4-line LCD
Standard Ranges	(4-wire Wye) 115/208 VAC; 100, 200, 400, 800, 1600, 3200 A (4-wire Delta) 277/480 VAC; 100, 200, 400, 800, 1600, 3200 A (4-wire Wye) 115/208 VAC; 100, 200, 400, 800, 1600, 3200 A (4-wire Delta) 277/480 VAC; 100, 200, 400, 800, 1600, 3200 A
Modem Interface	Cable: UL-Listed/rated telephone cord, 4-cond. 300 VAC, stranded cond., 22-26 AWG. Cable Connector: RJ-11 IDC termination Ckt Input Isolation: 5.3k VAC Baud Rate: 9600
RS-485 Serial Communications	Cable: UL-Listed/rated telephone cord, 4-cond. Ground-isolated +/-5.4Vdc Cable Connector: RF-45 male IDC or screw terminal termination Circuit Input Isolation: 5.3kVAC Max Cable Distance: 2000 feet Max Network Nodes: 64 cabling nodes (including master) Baud Rate: 9600
Load Control Contacts	Contact Closure: Set by user Contact Rating: 28Vdc@10A; 240VAC@10A Mating Connector: Weidmuller PN 1526510000 Isolation Voltage: 1.5kVAC for one minute
Recommended In-Line Fuse	Manufacturer: Littelfuse Mfg. Part No.: KLDR.100 Rating: 100mA, time-delay, 600VAC cartridge fuse
Battery Cell	Description: Non-rechargeable cell used for memory retention Manufacturer: Eagle-Picher Mfg Part No.: LTC-3PN Working Voltage: 3.5Vdc Current Capacity: 350mAHr Electrolyte: Lithium Thionyl Nitrate

Table 2.0.1 Class 3000 meter technical specifications.

3.0 Safety Label Definitions and Information

The Class 3000 meter may contain one or more of the following labels. Operator(s) should familiarize themselves with the meaning of each label to minimize risk.



The presence of this label is a cautionary indicator identifying a danger risk. The manual should be consulted prior to proceeding.



The presence of this label indicates an electrical shock hazard exists in the location or area where the label is placed. Prior to proceeding, the MAINS power must be disconnected and the manual consulted for safety information.

4.0 Precautionary/Safety Information

CAUTION: Internal circuit card components are extremely sensitive to electrostatic discharge. Be careful not to touch internal circuitry prior to discharging any static buildup on your person. To discharge yourself, touch a grounded metal object such as conduit or an earth-grounded metal enclosure.



WARNING: High voltages present on main PCB terminal block TB1. Risk of serious injury and/or electrical shock exists. Prior to performing any wiring operations, review all contents of the user manual and de-energize the MAINS power switch. Only qualified personnel should perform installation wiring. Installation wiring must comply with all local and national electrical codes.



WARNING: Failure to ground the enclosure creates a possible shock hazard. Do not operate the Class 3000 meter without a protective earth wire attached securely to the PE terminal screw. After installing protective earth wiring, secure the screw tightly (10 N-m torque.)



WARNING: NEVER open front panel of unit while unit has MAINS power applied. Failure to comply can increase the risk of serious injury and/or electrical shock.

5.0 Meter Installation

5.1 Mounting the Class 3000 Meter

Use appropriately sized mounting hardware to fasten the Class 3000 enclosure to the selected mounting surface. The four housing mounting holes are centered 8.75" H x 4" W.

Note: Units housed in NEMA 12/13 enclosed units must only be installed in indoor environments, where they will not be affected by the elements.

5.2 Meter Board Connections

1. *Installing a temporary ground for ESD protection:*
With all circuits de-energized, connect a temporary protective earth ground connection for ESD protection. **Prior to performing any unit wiring, be sure to discharge any static on your person.**
2. *Installing the Class 3000 protective earth ground:*
Connect an earth ground wire to the Class 3000 protective earth ground lug with a torque of 10 N-m.

Warning: Failure to attach the protective earth ground wire securely to the meter creates a potential shock hazard. Do not operate the meter without a protective earth ground connection securely installed.

3. *Wire Entry:*
Three 3/4" conduit openings are located on the bottom of the unit enclosure. These openings are used for bringing in MAINS power and for current sensor wiring. One of the openings can be utilized as an interface for the modem telephone line, low-voltage signals, relay contacts, and RS-485 communications wiring to the unit.

Route the appropriate cabling to and through the respective enclosure opening.

After installing the conduit fitting and conduit, verify that each conduit slip nut is securely tightened to its respective conduit fitting.

4. *Unit MAINS wiring:*
The 5-position terminal block J1, located at the bottom left corner of the main power board, is clearly labeled A, B, C, N (*neutral*) and GND.

Figure 5.2.1
Terminal Block J1



- A. Connect the NEUTRAL wire to the appropriate terminal block position.

5.2 Main Power Board Connections (continued)

NOTE: For 3-wire delta-type meters, Do NOT connect the NEUTRAL wire. Remove the terminal block screw for this position.

- B. Connect the three AC main power wires (Phases A, B and C) to their respective positions as labeled on terminal block J1. After all conductors are connected to each of their respective terminal block positions and tightened down, verify that each terminal block screw is securely fastened by gently tugging on each conductor.

Verify that no conductor wires are frayed or shorting to adjacent terminal block positions.

- C. Turn ON the AC main power input. The meter display will light up and scroll through 6 displays. Each display is visible for 10 seconds. Display screens are as follows:

Screen 1 - Total kilowatt-hours (kWh) consumed

Screen 2 - Peak demand (kW) with date & time stamp

Screen 3 - Actual load (kW) with preset date & time

Screen 4 - Average current (amps) per phase

Screen 5 - Average voltage (volts) per phase

Screen 6 - Power factor (PF) per phase

- D. Verify the voltage readings on Screen 5 using an AC voltmeter. Typical readings on each phase with respect to neutral are shown below. Readings should be +/- 10% range.

Meter Type	Nominal Voltage	Limits (+/-10%)
208/240V, 3 ϕ , 4 Wire	120 VAC	108 to 132 VAC
480V, 3 ϕ , 4 Wire	277 VAC	249 to 305 VAC
208/240V, 3 ϕ , 3 Wire	240 VAC	216 to 264 VAC
480V, 3 ϕ , 3 Wire	480 VAC	432 to 528 VAC

Table 5.2.1. Typical voltage readings.

Note: If you see the messages “Check Meter” or “Low Battery” on the display, refer to the section on module diagnostics.

Note: Meters are powered by phases A and B. The displayed voltages will be the measured AC voltage between phases.

5.3 Phasing of Line Voltage

The 3-phase AC power input must be in proper phase sequence. If the sequence is incorrect, there will be a message on the meter's display: *PHASE[2]. If Phase B and/or Phase C are missing, there will be a message on the meter's display: *PHASE[3]. (Refer to the section on module diagnostics if either of these messages are present.) When the line voltage is connected correctly, the meter's display will be blank (no message.)

A red LED on the main power board turns on if a line phase error is detected. This LED is labeled "PHASE ERROR" and is located on the top of the main power board.

Wait for the meter display to scroll to the voltage display. Verify that the meter reads correct voltages on all three phases. Repeat Step 5.2.4.D.

Once the meter displays the correct line voltages and there are no error messages, you are ready to connect the current sensors to the meter. Before continuing with the installation, verify that the six screens display as follows:

Screen 1 (kWh):	Should read 0.0 kWh; if not, should be reset.
Screen 2 (kW Peak Demand):	kW peak should read 0.0 kW. There will not be a date/time stamp yet. If there is a kW peak recorded, it should be reset later.
Screen 3 (Load/Clock Calendar):	Should read 0.0 kW load. The present date and time are shown. If the clock calendar reading is not correct, it should be set correctly later. The time-of-day clock should be running.
Screen 4 (Amps per Phase):	There should be 0.0 on all three phases.
Screen 5 (Average AC Volts):	See the chart shown in Step 5.2.4.D.
Screen 6 (Power Factor):	There should be 0.0 PF on all three phases.

Note: The meter will be reset later via the software during "startup" procedures. Resetting the kWh reading and clock calendar must be done at the host computer via the RS-485 communications link or modem.

5.4 Current Sensor Installation & Wiring

Once the AC voltages have been confirmed to be within acceptable limits, you are ready to install the current sensors. The main power board contains three orange connectors located at the bottom center of the board, TB1, TB2 and TB3. (See Figure 1.1.2, page 2.) TB1 is the input for phase A, and TB2 and TB3 are the inputs for phase B and C, respectively.

5.4 Current Sensor Installation & Wiring (continued)

The Class 3000 meter can be used with two types of current sensors:

1. Split-core current sensor. This sensor opens so that it can be attached around the circuit being monitored without interrupting power. Unless otherwise specified, all Class 3000 meters are supplied with this sensor type.
2. Solid-core current sensor. This sensor does not open and requires the monitored conductor to be removed from the circuit to install the current sensor. This type is only supplied when specified at time of order.

Note: The unit serial number label specifies if the unit is set up for split-core or solid-core current sensors.

5.4.1 Installing the Split-Core Current Sensor Assembly

1. Each phase being monitored will require one two-piece current sensor assembly. Open the two-piece current sensor assembly by releasing the nylon clamp using a flathead screwdriver.



2. Reassemble the current sensor assembly around the conductor(s) to be monitored. Ensure the current sensor halves marked "Load" are both facing the load side of the conductor. The colored arrow will be on the source side of the conductor being monitored and MUST be pointed in a clockwise direction around the conductor being monitored. Tighten the nylon clamp to complete the assembly.

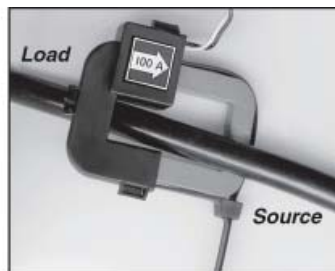

IMPORTANT: When looking from the source side of the conductor(s) being monitored, you should see the arrow on the current sensor assembly. The arrow should be pointing in a clockwise direction around the conductor(s) being monitored. If the arrow is not positioned on the source side, inaccurate readings will result.

5.4.2 Current Sensor Wiring

Once the current sensors are installed onto their appropriate phase conductors, you can begin terminating the current sensors onto the Class 3000 main board. The current sensors can be extended up to 500 feet for remote monitoring applications. To extend the length of the wires, use #22 AWG twisted-pair wire with one white and one black wire.

The easiest way to connect the current sensors is to use the meter's built-in current sensor diagnostics. To do this, there must be at least 1% of the meter's current rating (amps) flowing in each of the conductors being monitored. The Class 3000 meter's diagnostic program will provide data to ensure that the current sensor installation is done properly.

The current sensor connection points are located at the bottom right of the main power board. These three removable blocks are labeled TB1, TB2 and TB3. Each sensor connector has two terminals labeled "Black" and "White." Current sensors should be connected to the meter one at a time and verified using the current sensor diagnostic program.

Connect one of the current sensors to TB1 using the two-screw removable terminal plug. Insert the plug into terminal for TB1. Wait 5 seconds and look at the meter display.

If the meter displays an error message (see below), remove the plug from TB1 and plug into TB2 (Phase B). If an error message occurs with the sensor plugged into TB2, try again on TB 3 until the error message disappears.

The *SENSOR message will disappear when the current sensor is connected to the correct terminal (phase).

Error Messages: *SENSOR A
 *SENSOR A B
 *SENSOR A C

Note: A sensor error will also cause the red LED labeled "CT ERROR" to light up. This LED is located at the top right of the main power board.

Refer to the section on module diagnostics for assistance in troubleshooting these errors.

NOTE: When the E-Mon D-Mon® Class 4000/4100 meter is installed where the tenant has access to the electrical panel powering the meter, it is suggested that a dedicated breaker NOT be used to power the meter, as a dedicated breaker can be shut off and stop the meter from recording. If a dedicated breaker must be used, it should be a lockable style.

5.4.3 Main Power

After the meter circuit wiring has been examined for correctness, power may be applied to the circuit board. If the monitored circuit is under load, the LED in the meter's upper right hand corner will actively blink - indicating the amount of load by the frequency of its pulse. A heavy load will blink faster than a light load. Very light loads will result in an extended blink time.

5.5 Main Power & Current Sensor Wiring Diagrams

3-Phase, 4-Wire Installation Diagram

Line Voltage Connections: # 14-22 AWG

Sensor Connections: B = Black Lead
W = White Lead

* 1/10 A 600 VAC inline fuse per conductor.
Littelfuse part number KLDR.100.

** Neutral not used in delta system.

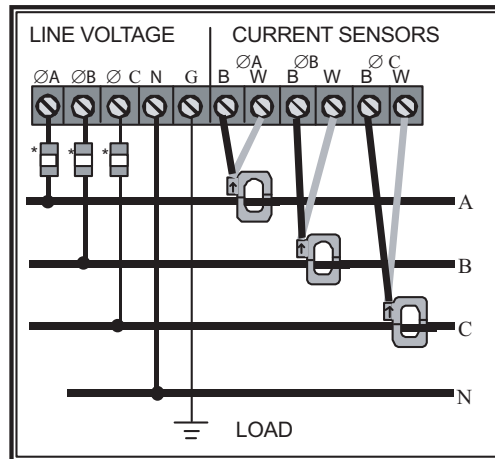

3-Phase, 3-Wire Installation Diagram

Line Voltage Connections: # 14-22 AWG

Sensor Connections: B = Black Lead
W = White Lead

* 1/10A 600 VAC inline fuse per conductor.
Littelfuse part number KLDR.100.

** Neutral not used in delta system.

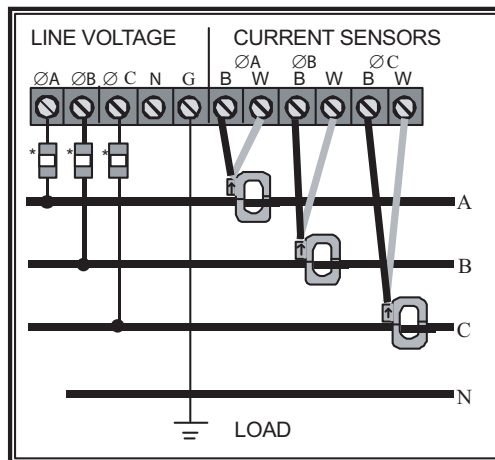

5.6 Line Voltage/Current Sensor Diagnostics

Following is a list of diagnostic messages that may appear on the meter display. DIAGNOSTIC MESSAGES SHOULD NOT BE ON CONTINUOUSLY WHEN THE METER IS INSTALLED PROPERLY AND IS IN WORKING ORDER.

5.6.1 Line Voltage Diagnostics

The diagnostics program detects line voltage faults by displaying one of two messages:

***PHASE[2]** or ***PHASE[3]**.

***PHASE[2]** indicates that the 3-phase line voltage is not hooked up in the proper phase sequence. This message should never be seen on the display continuously. The meter will not display correct electrical data in this condition. The phase sequence problem must be remedied in order for the meter to work properly.

***PHASE[3]** indicates that the line voltage is missing on Phase B and/or Phase C. This message will appear whenever the power on either Phase B or Phase C is off. Screen 5 (Voltage per Phase) will also indicate a loss of line voltage.

5.6.2 Current Sensor Diagnostics

The load current must be at least 1% of the meter's rated load in order to use the diagnostic function. Current sensor diagnostics can detect:

1. Reversed current sensors
2. Incorrect phase correspondence
3. Unusually low power factor (0.642 or lower)

Two different sensor diagnostic messages are used: ***SENSOR** or ***PH-ANGLE**.

***PH-ANGLE (ABC)** is used to detect the swapping of current sensor phases. This message could (in some rare cases) indicate an extremely low power factor condition. This message may appear intermittently due to changes in line conditions. It should never be on continuously. (See Section 5.4.1.)

NOTE: If you have connected the current sensor to all three terminals and the error message is still appearing, reverse the black and white wires and repeat the previous steps until the correct connection is found.

If the ***SENSOR** error message disappears, you have found the correct sensor connection; however, the current sensor was not installed properly around the conductor, or the sensor wires were extended and not spliced together correctly. Correct the sensor installation, reconnect the black wire to the black terminal and the white wire to the white terminal on the plug and reinstall the plug into the correct phase terminal for that current sensor. The error message should disappear and the current sensor is now installed properly.

5.6.2 Current Sensor Diagnostics (continued)

If the **SENSOR* message does not disappear at any time while trying all 3 inputs both ways, check the AC voltage input from the current sensor between the black and white wires using an AC voltmeter. It will read approximately zero volts indicating that the load current is very small (or zero) or the current sensors are not secured properly (tight connection between core halves or lead splices not secure.)

Once the first current sensor is connected properly and the error message disappears, repeat the previous procedure for the remaining two current sensors. When all error messages have disappeared and all sensors are installed correctly, the meter is operational.

5.6.3 Other Diagnostic Messages

****CHECK METER****

This hardware diagnostic message indicates that something is wrong with the metering circuit. The metering circuit's output is not operating when this message is present on the display. If this message appears, turn off power to the meter, disconnect the current sensor inputs and then momentarily connect a shorting link across each sensor input at TB1, TB2 and TB3. Reconnect the current sensor inputs and power up the meter. If the ****CHECK METER**** message is still present at this point, contact E-Mon at (800) 334-3666.

**** LOW BATTERY ****

This message indicates that the internal backup battery is missing or that the battery needs to be replaced. Contact E-Mon at (800) 334-3666 for battery replacement information.

**** METER SETUP ****

This message indicates that the meter is not initialized, or that the battery has been removed and replaced. Check the red LED D4 (labeled "CPU ACTIVE"). Normally, this LED should flash once per second. When the meter is not initialized, this LED will flash twice every second. If this message appears, try initializing the meter via the E-Mon Energy™ software. If after initialization the message is still displayed, or if E-Mon Energy software is not available, contact E-Mon at (800) 334-3666.

***OVERLOAD (ABC)**

This message indicates that the meter has detected an analog overload on one or more current sensor inputs. Overloaded sensor inputs are indicated by phase (ABC). This message is intended as a diagnostic for current sensor installation to warn of a sensor that is underrated. DURING NORMAL OPERATION AN *OVERLOAD MESSAGE INDICATES THAT THE CONDUCTORS BEING MONITORED ARE AT OR ABOVE 110% OF THE FULL-SCALE CURRENT. This message should not be on continuously. If the cause of the overload cannot be determined or if the current sensors have an incorrect current rating, contact E-Mon at (800) 334-3666.

5.7 RS-485 Wiring

RS-485 communication allows a computer or modem to communicate with one or more Class 3000 meters. You can connect as many as 52 meters along a 4000-foot RS-485 cable run.

There are two connection methods, daisy-chain and wire terminal, for RS-485 communications.

Daisy-Chain Method

This is the simplest method for connecting meters together.

Figure 5.7.1.
Daisy-chain configuration.

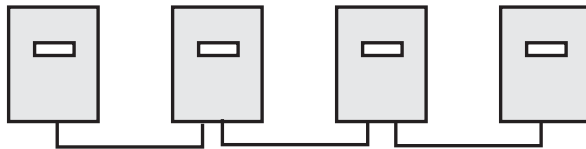

If you are using RJ-11 cable connections (common telephone wire) simply join all meters together so that all the meters are linked together. Each meter has two jacks available for RS-485 to facilitate making a daisy chain. Cables must be assembled so that the plugs are wired pin-to-pin.

Wire Terminal Method (J13 on CPU Board)

1. Connect the HI terminal on J13 of each meter together so that all of the HI terminals on all meters are linked, HI to HI to HI, etc.
2. Connect the LO terminal on J13 of each meter together so that all of the LO terminals on all of the meters are linked, LO to LO to LO, etc.
3. Connect the GND terminals on J13 of each meter so that all of the GND terminals on all of the meters are linked, GND to GND to GND, etc.

After performing the steps in either of these methods, all of the meters will be connected in a daisy chain. Now, select a device to communicate with this network of Class 3000 meters.

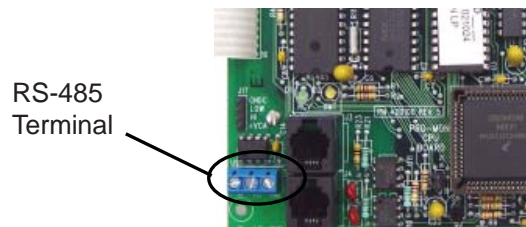

Internal Modem

An optional internal modem inside one meter will communicate with others via the RS-485 network. Simply connect one of the two telephone jacks on the modem to the telephone line to complete the installation.

NOTE: The modem option has a 9-pin D-connector labeled "RS232." **DO NOT USE THIS CONNECTION.**

5.7 RS-485 Wiring (continued)

Local Computer

A local computer somewhere in the building can communicate with the RS-485 network. The computer must be connected to an RS-232 key. The RS-232 key is then connected to one of the available RS-485 jacks in the meter using an RJ-11 cable.

NOTE: Don't confuse the modem's telephone jacks with the RS-485 jacks!!!

NOTE: When using one meter with an external modem, only the telephone line is connected. RS-485 is not needed.

5.8 RS-232 Communications

Figure 5.8.1.
RS-232 configuration.

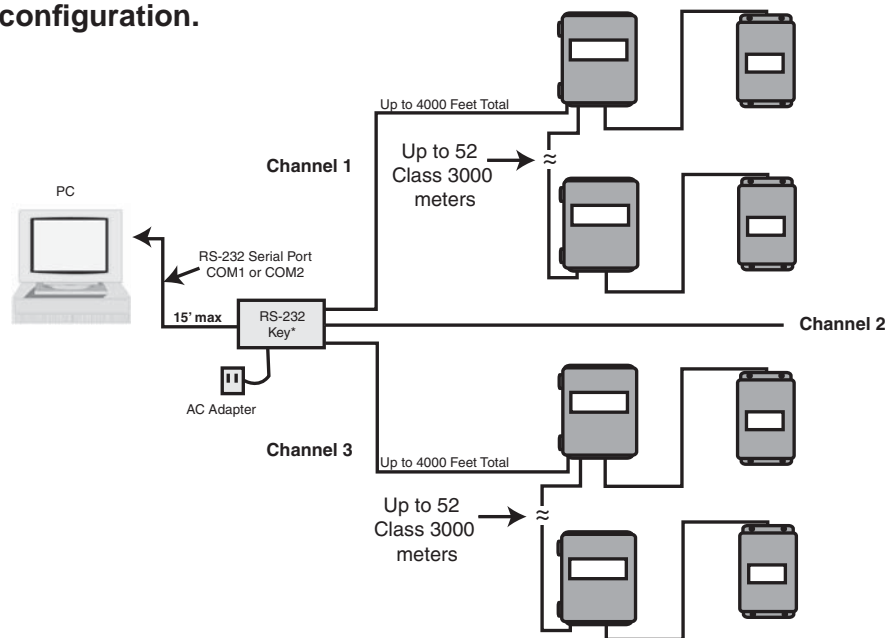

5.8.1 Hardwired System using the RS-232 Communication Key

(See Figure 5.8.1.)

The RS-232 communications key allows you to connect Class 3000 meters to a personal computer that has the E-Mon Energy™ software installed. The computer communicates with the meters through the RS-232 key.

The RS-232 key must be located within 15 feet of the host computer.

5.8.2 Connecting the RS-232 Key to the Computer

The RS-232 key is supplied with:

- a. (1) 8-conductor cable fitted with RJ-45 plugs
- b. (1) DB-9 serial COM port adapter
- c. (1) AC adapter that converts 120VAC to 7VAC for powering the RS-232 key

Connection Steps:

1. Connect the 8-conductor cable to the left-side jack (labeled "RS232") on the rear panel of the RS-232 key.
2. Connect the appropriate COM port adapter (DB-9) to the serial port on the back of the computer. Plug the 8-conductor cable from the RS-232 key into the COM port adapter.
3. Connect the 7VAC AC adapter into the rear panel input on the RS-232 key.
Plug the adapter into a 120VAC outlet. On the front panel of the RS-232 key, two LEDs (POWER ON and AC ON) will light up.

NOTE: When the E-Mon Energy™ software is accessed on the computer, a third LED (RS232 READY) will turn on. This indicator will light up as soon as the E-Mon Energy software is booted up and the correct COM port is set up via the settings provided in the software's Locations menu.

5.8.3 Connecting Class 3000 Meters to the RS-232 Key using RS-485

On the rear panel of the RS-232 key, there are three jacks labeled as channels A, B and C. These are RS-485 serial communications ports used to connect the meters. Each of these channels can be connected to as many as 52 individual meters over a total cable distance of 4,000 feet. Channels are independent and must not be connected to each other. (see Figure 5.8.1.)

Modular Plug Method

This simple method requires using 4 stranded conductors inside a cable that is fitted with an RJ-11 type plug for 4-conductor modular systems at each end of the cable.

*Do not use any pre-made telephone cables.

1. Plug the 4-wire RJ-11 cable/plug assembly into Channel A on the RS-232 key. Connect the other end of this cable to the meter via one of the two RS-485 ports at the top left on the Class 3000 meter main power board.
2. The unused RS-485 port is used to connect another cable to the next Class 3000 meter. This is called a daisy-chain connection, and can be done repeatedly to connect up to 52 individual Class 3000 meters.

5.8.3 Connecting Class 3000 Meters to the RS-232 Key using RS-485 (cont.)

NOTE: The total combined cable length must not be more than 4000 feet.

3. Each meter has one yellow and one green LED located directly below the RS-485 jacks. If the system is properly wired, these two LEDs will be OFF. These LEDs will flash when the computer and meter are communicating.

Terminal Block Method

Class 3000 meters may also be daisy-chained using a 3-conductor cable. Instead of using the two modular jacks for the RS-485 daisy chain, you can use J20 at the bottom right corner of the meter's main power board.

Remove J20 and attach the wires using the screw terminals inside the plug housing.

1. Daisy-chain the Class 3000 meters by connecting:
 - All HI terminals together
 - All LO terminals together
 - All GND terminals together** This requires putting two wires into each of the three terminals.
2. Connect to the RS-232 key. You will need to attach an RJ-11 modular plug to the cable that serves the RS-485 system. On each channel on the back of the RS-232 key, the pin-out for each channel is as follows:

PIN1 - Not Used
PIN2 - GND
PIN3 - HI
PIN4 - LO

NOTE: It is ok to use J20 with the modular jacks if needed.

5.9 Modem Wiring

Figure 5.9.1.
Modem configuration.

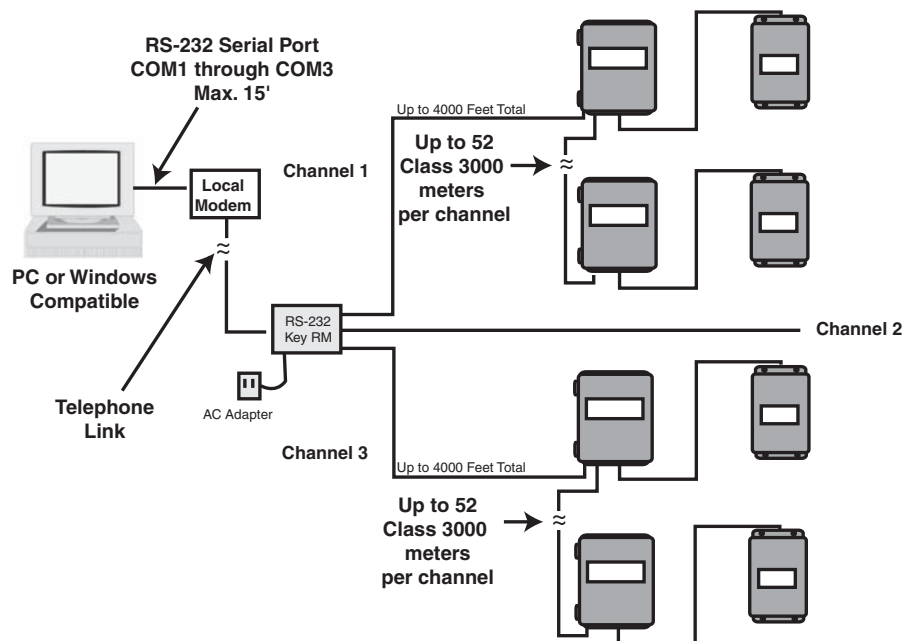

5.9.1 Built-In Modem (RS-232 KEY RM)

The RS-232 key with built-in modem connects the entire RS-485 network of Class 3000 meters to a telephone line.

** Refer to Section 5.8.3. Connect the RS-485 network via Method 1 or 2.

On the back panel of the RS-232 key/modem, the left jack (RS232) is not used in most cases since there is no local host computer.

The two jacks at the top center of the rear panel on the RS-232 key/modem are for connecting the phone line. Connect one of these two jacks to the telephone line.

IMPORTANT: The telephone line should be dedicated exclusively to the automatic meter reading system. Never connect to a telephone line used by other modems or fax machines. If there are telephones connected to this phone line, the proprietor must be aware that all phones must be on “hook” in order for the modem to work. A dedicated phone line is suggested for system reliability.

5.9.2 External Modem

1. All meters should be connected to the RS-232 key as described above.
2. DISCONNECT POWER TO THE RS-232 KEY. Remove the cover by removing the 2 screws from the bottom of the enclosure.
3. On the circuit board, locate the blue jumpers J7 (MODEM) and J8 (ex-MODEM). If these jumpers are set in the DIRECT position, you must move the jumpers so they are set in the MODEM position. Replace the cover and secure the enclosure.
4. Connect the RS-232 key to the external modem using the supplied 8-conductor flat modular cable.
5. Connect the 7VAC adapter to the power input on the back of the RS-232 key and plug it into a 120VAC outlet.

IMPORTANT: The modem should use a phone line that is dedicated exclusively to the AMR system. Do not use a phone line that is shared by another modem or fax machine.

5.9.3 Baud Rate Selection

The communication baud rate is selected by means of a jumper on the circuit board. There are three (3) selections: 19200, 9600 (factory default) and 2400.

1. Select 9600 when using the Class 3000 meter with a modem.
2. The baud rate on the meter must always match the baud rate selected in the E-Mon Energy software; otherwise, communications will not work.
3. After a baud rate change, press CPU Reset to register the change.
4. All meters in the daisy-chain circuit must be set at the same baud rate.

5.10 Modbus Wiring

The Class 3000 Modbus meter communicates with building automation equipment over a 2-wire (3-conductor) RS-485 network using Modbus RTU protocol. The meters are networked in a daisy-chain configuration (Section 5.7) with BELDEN 1120A cable or equivalent. The cable rating of 600V allows the RS-485 network to be connected to 480-volt meters. Up to 52 meters can be installed on a network string. The maximum combined length of all daisy-chained cables must not exceed 4000 feet.

5.10 Modbus Wiring (continued)

The meter-to-network connection is through the 3-screw terminal which is located on the CPU board, on the door of the meter. Figure 5.10.1 shows the terminal location and correct wiring method for Modbus communication.

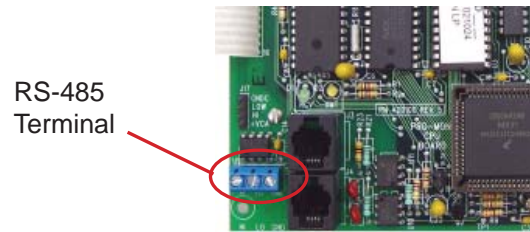

The meter is shipped with a Modbus ID number of 01. This must be changed if the network has more than one meter installed. The change must be done before the meter is introduced into the network. The meter can be numbered from 1 to 247. There can be no duplicate numbers on a network, so caution must be taken when assigning a meter ID number prior to its installation on the RS-485 network.

Figure 5.10.1 Modbus Installation Overview

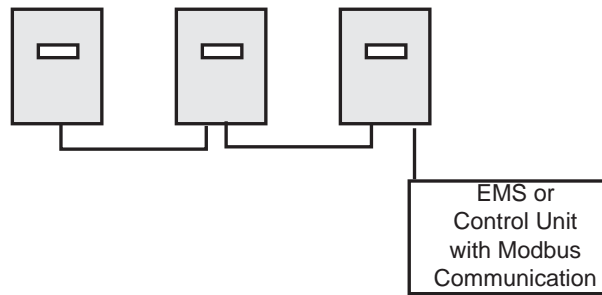

5.11 Ethernet Communication

Class 3000 Ethernet/IP Addressable meters can be tied into a local Ethernet network individually, or a single Ethernet-connected meter can communicate with multiple RS-485 daisy-chained conventional class 3000 meters using a single IP address.

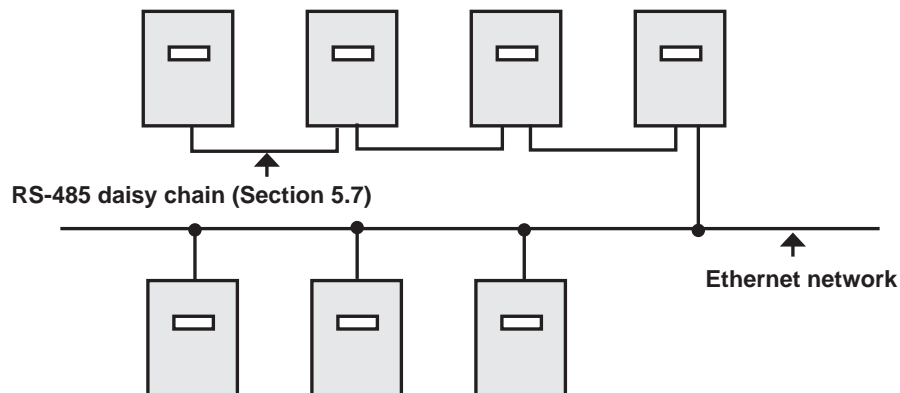

6.0 Multiple-Load Monitoring

The E-Mon D-Mon Class 3000 meter provides extreme flexibility by allowing additional sets of current sensors to be used in parallel so multiple load locations can be monitored by one meter. This feature allows a totalized display readout from two or more load circuits.

You may use parallel sensors to monitor specific breakers from one panel, specific breakers from more than one panel, two or more complete panels, etc.

When paralleling current sensors, the following rules must be followed for accurate readings:

1. Current sensors must be installed in complete sets of three, with a maximum of three sensors installed in parallel per phase.
2. All sensors used in parallel must be of the same amperage rating (all 100-amp, all 400-amp, etc.) The rating is determined by the current rating of the meter. For example, a 200-amp meter must use extra sets of 200-amp current sensors.
3. All locations being monitored must have the same power source. A 480-volt meter cannot monitor a 208-volt load, nor can a meter monitor two-480 volt loads if they are from different originating power sources or from different transformers.
4. Multiply the meter display readings by the number of sets of current sensors installed. Example: Meter readings of 5 kWh with 2 sets of current sensors - 10 kWh is the actual usage. ($5 \times 2=10$.)

NOTE: One set of current sensors equates to three sensors, one per phase. The multiplier only applies when extra sets of current sensors are installed on one meter. If you are using only one set of three current sensors, the multiplier is not required.

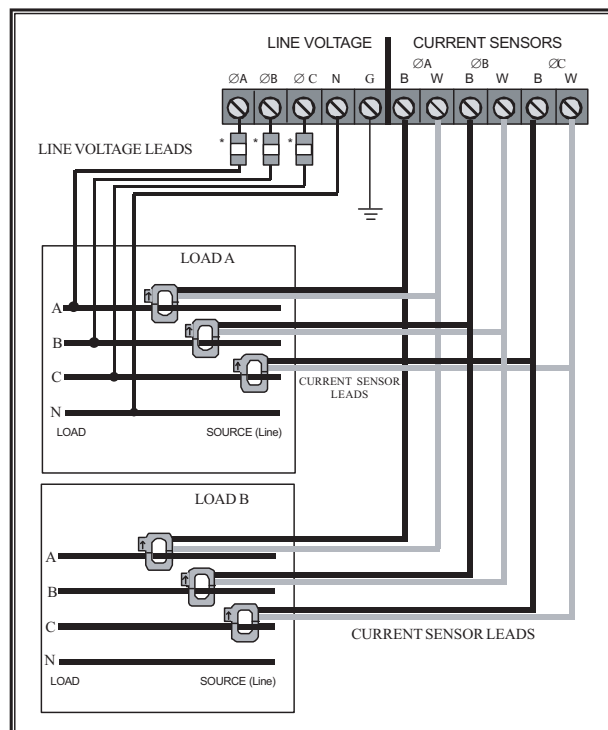

Figure 6.0.1
Multiple-load
wiring diagram.

7.0 Preventative/Scheduled Maintenance

The unit is shipped in a calibrated and fully functional tested condition. Since the unit is factory-calibrated using proprietary firmware algorithms, no internal unit adjustments are necessary.

This unit contains no internal adjustments, so no preventative or scheduled maintenance is required.

No cleaning or decontamination procedures are required for this instrument.

8.0 Lithium Battery Replacement

The Class 3000 meter has a lithium battery cell, which is used to retain the contents of SRAM and the RTC during power outages. The battery's life expectancy is greater than 8 years.

Operating Temperature Range	-40 to +95 degrees Celsius
Nominal Working Voltage	3.5Vdc output
Nominal Current Capacity	350 mAHr
Cell Chemical	Lithium-thionyl chloride
Manufacturer	EaglePicher
Manufacturer Part Number	LTC-3PN

Table 8.0.1 Battery specifications at 25 degrees Celsius.

Warning: Only replace battery with exact manufacturer and manufacturer part number as specified above.

The battery cell is mounted in a socket on the upper leftside of the display board. If the battery drops below 2.4Vdc in capacity, a battery symbol will light up in the left margin of the display, denoting a low battery condition. Additionally, the internal unit firmware will set a flag to indicate the low battery condition. When the unit data is next downloaded, the monitoring facility will be alerted of the low battery condition and will schedule a service call.

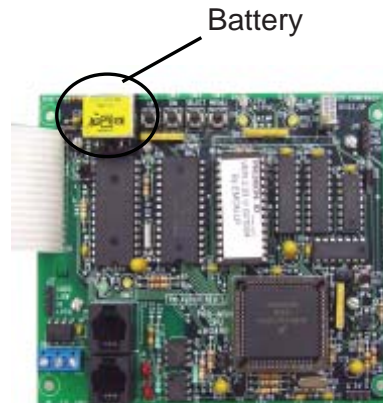

Figure

8.0 Lithium Battery Replacement (continued)

Use the following procedure to replace the lithium battery cell.

CAUTION: The battery is not completely discharged; therefore, **DO NOT** short the terminals on the battery with any conductive material.

CAUTION: Internal circuit card components are extremely sensitive to electrostatic discharge. Be careful not to touch internal circuitry prior to discharging any static buildup on your person. To discharge yourself, touch a grounded metal object such as conduit or a metal enclosure interior.

1. Disconnect power from the meter at the unit external circuit breaker.
2. Remove the battery from its socket and place on a non-conductive surface.
3. Install new battery into the PCB battery socket.

NOTE: The main power board battery socket is keyed to prevent the user from inserting the new battery in the wrong polarity. No damage to the unit or battery will occur if battery is inadvertently installed in the wrong direction.

4. Visually inspect new battery to verify that all leads are fully inserted into their respective socket positions.
5. Dispose of the used battery in accordance with the manufacturer's (EaglePicher's) instructions.

9.0 Class 3000 Meter Features

Display Hold Feature

You can “lock” the scrolling display so that it will stay locked on any one of the six screens. On the inside of the door, locate the 4 buttons at the top of the CPU board: Up, Down, Select and Menu. (These buttons are illustrated on the previous page.)

To stop the display from scrolling, follow these instructions:

The Select button is used to lock the meter’s display so that it stops scrolling and the display remains on one screen.

Use the Up and Down buttons to choose which of the six screens you would like to display.

Press the Select button. At the top of the display, you will see the message HOLD1. This will lock the display for 1 HOUR.

Note: The display hold feature has different selectable time periods.

Pressing Select again will show the message HOLD6. This will lock the display for 6 HOURS.

Continuing to press the Select button will provide additional timing choices:

HOLD12: Locks the display for 12 HOURS

HOLD24: Locks the display for 24 HOURS

HOLD: Locks the display indefinitely

To exit the HOLD mode:

Press the Select button as many times as needed until the HOLD message disappears from the display, or simply press the CPU RESET button located near the right center of the CPU board.

** Be sure to exit from the HOLD mode when you are done using this feature.

10.0 Reading the Class 3000 Meter Display

The Class 3000 meter feature six different displays showing information in 10-second scrolling intervals. Explanations of these displays are as follows:

Screen 1: Total Kilowatt-Hours (kWh)

KILOWATT-HOUR TOTALS	
375.4 kWh	
< >	

Screen 2: Peak Demand (kW) with Date & Time Stamp

KW Peak:	8.50 kW
ON DATE:	07/01/08
AT TIME:	15:50
< >	

Screen 3: Actual Load (kW)

LOAD:	8.50 kW
< >	

Screen 4: Average Current (amps) Per Phase

PH-A:	4.5 AMPS
PH-B:	4.5 AMPS
PH-C:	4.5 AMPS
< >	

Screen 5: Average Voltage (volts) Per Phase

PH-A:	112.6 VOLTS
PH-B:	112.4 VOLTS
PH-C:	111.7 VOLTS
< >	

Screen 6: Power Factor (PF) Per Phase

PH-A:	100% PF
PH-B:	96.1% PF
PH-C:	98.5% PF
< >	

11.0 Frequently Asked Questions

- Q. When providing line voltage to the meter, can I tap off of the same breaker I am monitoring?**
A. Yes, the voltage can be pulled from the same breaker being monitored.
- Q. Can the meter's line voltage wires be run in the same conduit as the sensor leads?**
A. Yes. There will be no effect if the sensor leads and line voltage wires are run in the same conduit.
- Q. Can the meter's communication wires and line voltage be run in the same conduit?**
A. It is not recommended to run these wires together due to noise concerns and their effects on the communications signal integrity. Communications wires can be routed separately using the 1/2" conduit port.
- Q. How do I find the cost for kWh and kW to bill my tenants?**
A. Your local utility bill should list the cost per kWh and kW. If not, simply call your utility and ask them to provide you with the cost per kWh and kW.
- Q. What size wire do I use for the line voltage leads?**
A. These wires are normally sized at #14 AWG, but be sure to confirm this requirement with your local and national electrical code requirements.
- Q. What size wire should I use to extend the current sensor leads?**
A. These wires are normally 14-22 AWG, twisted-pair arrangement. Consult your electrical code for proper wiring requirements.
- Q. The load I need to monitor has parallel feeds. How do I install the current sensors for this application?**
A. There are two ways you can monitor parallel feeds. The easiest and preferred method is to clamp the sensors around all feed wires for each phase. The second way to monitor parallel feeds is to clamp the sensor around one of the feed wires for each phase. When you read the Class 3000 meter, the final reading must be multiplied by the number of feed wires for each phase.
- Q. I have two subpanels I would like to monitor with one Class 3000 meter. These subpanels are fed by different transformers in the building. Can I parallel sensors and monitor both panels with one meter?**
A. No. These panels cannot be monitored with one meter because they are different power sources. When you parallel current sensors, all loads being monitored must be from the same voltage source.
- Q. I have 5 breakers in one subpanel I would like to monitor with one class 3000 meter. Can this be done without having to parallel current sensors?**
A. Yes. Simply run all the breaker wires through one set of current sensors. Make sure all A-phase circuits are run through the A-phase sensor, and the same for B & C phases. The meter should be sized by the highest amount of current being monitored by one sensor.
- Q. I've gone through the troubleshooting guides and I still can't get my class 3000 meter to work. What should I do?**
A. Before removing the unit, contact E-Mon's technical services department at (800) 334-3666. E-Mon's technical department will assist you in detailed troubleshooting of the meter installation and assist you in getting the unit running without having to remove and/or return it.

12.0 Meter Limited Warranty

Subject to the exclusions listed below, E-Mon will either repair or replace (at its option) any product that it manufactures and which contains a defect in material or workmanship.

The following exclusions apply:

1. This Limited Warranty is only effective for a period of (18) eighteen months following the date of manufacture when installed in accordance with manufacturer's instructions by qualified personnel.
2. E-Mon must be notified of the defect within ninety (90) days after the defect becomes apparent or known.
3. Buyer's remedies shall be limited to repair or replacement of the product or component which failed to conform to E-mon's express warranty set forth above.
4. Buyer shall be responsible for all freight costs and shall bear all risk of loss or damage to returned goods while in transit.
5. This Limited Warranty does not cover installation, removal, reinstallation, or labor costs, and excludes normal wear and tear. Buyer shall provide labor for the removal of the defective component or item and installation of its replacement at no charge to E-Mon.
6. This Limited Warranty does not cover any product if: (i) a product is altered or modified from its original manufactured condition, (ii) any repairs, alterations or other work has been performed by Buyer or others on such item, other than work performed with E-Mon's authorization and according to its approved procedures; (iii) the alleged defect is a result of abuse, misuse, improper maintenance, improper installation, accident or the negligence of any party; (iv) damaged as a result of events beyond E-Mon's control or other force majeure events or (v) used in conjunction with equipment, components, accessories, parts or materials not supplied or approved by E-Mon.
7. This Limited Warranty is limited to the obligation to repair or replace the manufactured product. This is the sole and exclusive remedy for any breach of warranty. IN NO EVENT SHALL E-MON BE LIABLE FOR ANY INDIRECT, INCIDENTAL, SPECIAL, CONSEQUENTIAL OR PUNITIVE DAMAGES (INCLUDING ANY DAMAGE FOR LOST PROFITS) ARISING OUT OF OR IN CONNECTION WITH THE FURNISHING OF PRODUCTS, PARTS OR SERVICES, OR THE PERFORMANCE, USE OF, OR INABILITY TO USE ANY PRODUCTS, PARTS OR SERVICES, SALE OF OR OTHERWISE, WHETHER BASED IN CONTRACT, WARRANTY, TORT, INCLUDING WITHOUT LIMITATION, NEGLIGENCE, OR ANY OTHER LEGAL OR EQUITABLE THEORY.
8. EXCEPT AS EXPRESSLY PROVIDED HEREIN, E-MON MAKES NO WARRANTY OF ANY KIND, EXPRESS OR IMPLIED WITH RESPECT TO ANY PRODUCTS, PARTS OR SERVICES PROVIDED BY E-MON INCLUDING, BUT NOT LIMITED TO, THE IMPLIED WARRANTIES OF MERCHANTABILITY AND FITNESS FOR A PARTICULAR PURPOSE. PRODUCTS OR COMPONENTS DISTRIBUTED, BUT NOT MANUFACTURED, BY E-MON ARE NOT WARRANTED BY E-MON AND BUYER MUST INSTEAD RELY ON THE REPRESENTATIONS AND WARRANTIES, IF ANY, PROVIDED DIRECTLY TO THE BUYER BY THE MANUFACTURER OF SUCH PRODUCT OR COMPONENT.