

E-Mon D-Mon[®] Installation Manual

Class 4000 Single-Phase, Single-Point KWH Meter

Class 4100 Single Phase KWH Meter
with Optional Wireless RF Communications



Dear Valued Customer,

We are pleased that you chose to buy one of our products, and want you to be just as pleased with owning it. Before installing your new E-Mon product, please read the information on the following pages carefully.

We believe that you will find the E-Mon D-Mon meters easy to install and to use for monitoring and evaluating your electrical usage.

To be sure that you are 100% satisfied with your products, we provide toll-free technical and sales support Monday through Friday, 8:00 am to 7:30 pm, EST: (800) 334-3666. You may also reach us via email at info@emon.com.

If you have questions, we can handle them quickly and effectively with a telephone call. Please let us try to help you BEFORE you remove your meter. And to help us help you, we ask that you have all relevant information on hand when you call (model or part numbers, nature of difficulty, etc.)

Be sure to forward this manual to the owner after installation is complete, so that they may use it as a reference guide when reading the E-Mon D-Mon meter.

Thank you.

Table Of Contents

Section 1.0	Introduction	Page 1
Section 1.1	Internal Electronic Assemblies	Page 2-3
Section 2.0	Meter Technical Specifications	Page 4
Section 3.0	Safety Label Definitions	Page 5
Section 4.0	Precautionary and Safety Information	Page 5
Section 5.0	Meter Installation	Page 6
Section 5.1	Mounting the Meter	Page 6
Section 5.2	Main Power Board Connections	Page 6
Section 5.3	Current Sensor Installation and Wiring	Page 7
Section 5.4	Main Power	Page 8
Section 6.0	Features & Operating Guide	Page 9
Section 6.1	RF Wireless Option	Page 9
Section 7.0	Troubleshooting Guide	Page 10
Section 8.0	Information For The Owner/Manager	Page 11

1.0 Introduction

The E-Mon D-Mon Class 4000/4100 meter is a 1 or 2-element meter with optional RF communications (Class 4100). The device is used to monitor electric power usage of individual loads after the utility meter and display kWh consumption on a direct reading digital display. With the Class 4100 wireless RF option, it will provide kWh and kW data for automatic meter reading. Installation must only be performed by **qualified personnel and in accordance with these instructions and all applicable local and national electrical codes**. E-Mon and its representatives assume no responsibility for damages or injury resulting from the improper installation of this meter.

Verify the input voltage rating and configuration on the unit panel label to ensure that it is suitable for the intended electrical service. Class 4000/4100 meters labeled for 120/208V service **MUST NOT** be installed on service feeds of 277/480 volts.

Verify that the Class 4000/4100 meter's current sensors are sized suitably for the load to be monitored. Compare the color of the arrows on the current sensors to the chart below to confirm the correct sensor is being used.

Sensor Arrow Color code	Sensor Rating (Amps)
Brown	100 A
Red	200 A

Table 1.0.1. Sensor arrow color codes.

CAUTION: Internal circuit components are extremely sensitive to electrostatic discharge. Prior to handling or touching internal circuitry, discharge any static buildup on your person. To discharge yourself, touch a grounded metal object such as conduit or an earth-grounded metal enclosure.

WARNING: Use of this instrument, the E-Mon D-Mon Class 4000/4100 meter, in a manner inconsistent with this manual or not specified by the manufacturer in writing, can cause permanent damage to the unit and/or serious injury to the operator. The protection and safety features provided by this equipment may become impaired or otherwise compromised.

Note: If any troubles arise during the installation or functional verification operations, do not immediately remove the unit. Before removing the unit, contact E-Mon's technical support and/or engineering department at (800) 334-3666. E-Mon's technical department will assist you in detailed troubleshooting of the Class 4000/4100 meter installation and assist you in getting the unit operating correctly.

1.1 Internal Electronic Assemblies

The unit is comprised of one or two subassembly boards, the meter board and the optional RF board (Class 4100). Both circuit cards are mounted inside the non-metallic enclosure.

Note: Units are suitable for indoor applications only.

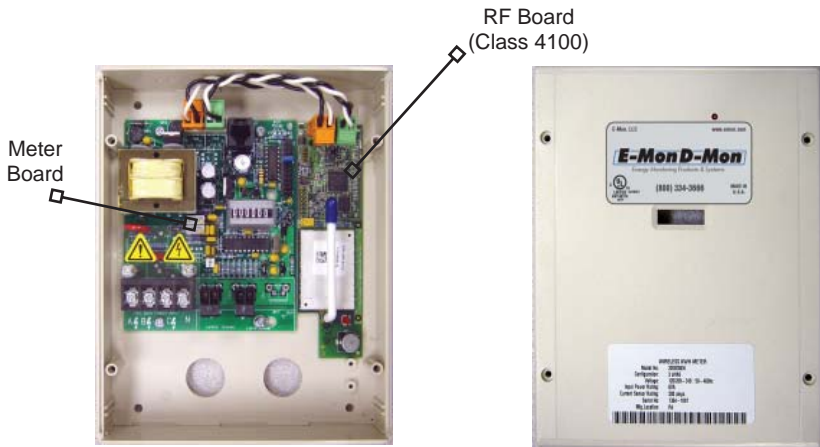
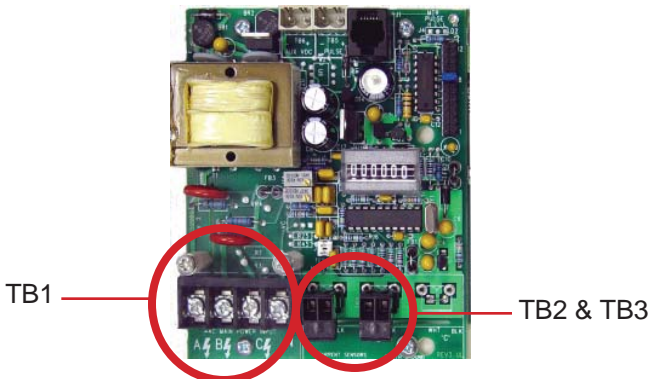

Figure 1.1 Internal electronic assemblies.

1.1.1 Meter Board

Connections to this board include the MAINS input voltage and current sensors. The MAINS input terminals (TB1) are covered with a protective clear shield for safety purposes. The current sensor assemblies interface to two header connections, TB2, and TB3. Each header connector input corresponds to an input voltage phase; care must be exercised to ensure that each current sensor is connected to the correct input header.

Figure 1.1.1 Meter board connections.



1.1.1 **Meter Board (continued)**

The Class 4000/4100 meter displays electrical consumption (kWh) on its 6-digit, electro-mechanical display, and is read directly - without multipliers. An LED on the board pulses in response to the load, with the speed of the pulse indicating the amount of load (a heavier load will blink more rapidly).

1.1.2 **RF Board (Class 4100)**

The optional RF board (Class 4100) connects to the meter board via two pair of conductors. One pair supplies power (5 VDC) to the RF board and the other pair supplies a pulse signal that is stored as interval data. The accumulated data is normally transmitted on a daily basis through its on-board antenna. This data is transmitted pier-to-pier, then utilized for AMR (Automatic Meter Reading). The RF board operates in the 900 MHz range with a maximum transmitting power of 100 mw.

Figure 1.1.2 RF Board (Class 4100)

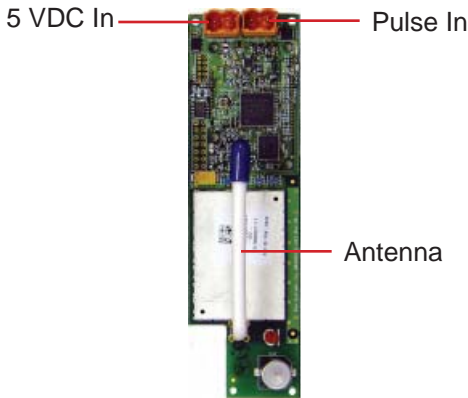

2.0 Meter Technical Specifications

Ordering Information: Define input voltage, current sensor rating and the RF option, in the format C-xxx-yyyy-zz, where

- C = number of conductors (2 or 3)
- xxx=input voltage (120 or 208 [120/208/240])
- yyy=current sensor rating (100, 200)
- zz=designated option (W=none [Class 4000], WT (RF transceiver [Class 4100])

Example:

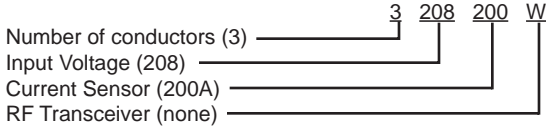

Input Voltage Configuration	2-wire 120-volt, 3-wire 120/240-volt, 3-wire 120/208 volt
MAINS Voltage Input	Up to 240 VAC
Input Power	6 VA maximum rating
Current Sensor Rating	Up to 200 amps RMS AC available
Power Factor	0.5 leading or lagging
Line Frequency	50-60 Hz
Metering Accuracy	Certified to ANSI C12.16 (+/-1% from 1-100% of rated load)
Voltage Operating Range	+/-10% of rated load
Temperature Range	-20 degrees C to +50 degrees C
Relative Humidity Range	0-95% non-condensing
Altitude	2000 meters maximum
Voltage Overload	+25% continuously; +100% for 20 cycles
Current Sensor Overload	100% for 1 minute without damaging meter
Pollution Degree	Degree 2 in accordance with IEC 664
Installation (Overvoltage) Category	Category III
Measurement Category	Category III
Enclosure Material	ABS 94VO
Display Readout	6-digit electro-mechanical
Standard Ranges	(2-wire) 120 VAC, 100, 200 Amp (3-wire) 120/208/240 VAC, 100, 200 Amp
Modem Interface	None
RS-485 Serial Communications	None
Load Control	None
Recommended In-Line Fuse	Manufacturer: Littlefuse Mfg Part No.: 313.100 Rating: 100mA, Slo-Blo, 250 VAC cartridge fuse

Table 2.0.1 Class 4000/4100 meter technical specifications.

3.0 Safety Label Definitions and Information

The Class 4000/4100 meter may contain one or more of the following labels. Operator(s) should familiarize themselves with the meaning of each label to minimize risk.



The presence of this label is a cautionary indicator identifying a danger risk. The manual should be consulted prior to proceeding.



The presence of this label indicates an electrical shock hazard exists in the location or area where the label is placed. Prior to proceeding, the MAINS power must be disconnected and the manual consulted for safety information.

4.0 Precautionary/Safety Information



WARNING: High voltages present on main PCB terminal block TB1. Risk of serious injury and/or electrical shock exists. Prior to performing any wiring operations, review all contents of the user manual and de-energize the MAINS power switch. Only qualified personnel should perform installation wiring. Installation wiring must comply with all local and national electrical codes.



WARNING: NEVER open front panel of unit while unit has MAINS power applied. Failure to comply can increase the risk of serious injury and/or electrical shock.

5.0 **Meter Installation**

5.1 **Mounting the Class 4000/4100 Meter**

Use appropriately sized mounting hardware to fasten the Class 4000/4100 enclosure to the selected mounting surface. The four mounting holes are located inside the enclosure and are accessed by removing the cover. The mounting holes are centered 6 13/16" H x 4 13/16" W.

NOTE: Units must only be installed in indoor environments, where they will not be affected by the elements.

5.2 **Meter Board Connections**

1. Wire Entry:

Two 1/2" conduit openings are located on the back of the unit enclosure. These openings are used for bringing in MAINS power and for current sensor wiring. Route the appropriate cabling to and through the respective enclosure opening.

After installing the conduit fitting and conduit, verify that each conduit slip nut is securely tightened to its respective conduit fitting.

2. Unit MAINS wiring:

The 4-position terminal block TB1, located at the bottom left corner of the meter board, is clearly labeled A, B, C, N (neutral). AWG 14 or 12 guage (stranded) conductors are typically utilized for this connection.

Figure 5.2.1.
Terminal block TB1.



- A. Connect the NEUTRAL wire to the appropriate terminal block position.
 - B. On 2-wire, 120 VAC installations, connect the AC main power wire to the Phase A position as labeled on terminal block TB1. On 3-wire 120/208 VAC installations connect the AC main power wires to Phase A and Phase B positions on terminal block TB1. After all conductors are connected to their respective terminal block positions and tightened down, verify that each terminal block screw is securely fastened by gently tugging on each conductor. Verify that no conductor wires are frayed or shorting to adjacent terminal block positions.
- #### 3. External Switch Mechanism/In-Line Fuse Installation

To ensure a safe installation, the Class 4000/4100 requires an external switch mechanism, such as a circuit breaker (max. 15 amps), be installed to the Class 4000/4100 MAINS input wiring. The switch mechanism must be installed in close proximity to the Class 4000 and easily reachable for the operator. This device must also be marked as the disconnecting device for the Class 4000/4100. Install 1/10 amp Slow Activation inline fuses with the suitable voltage rating for each conductor Phase at the MAINS Input to the meter. The fuses must be labeled to indicate voltage and current rating as well as element characteristics. The fuse element must be slow activating type.

5.3 Current Sensor Installation & Wiring

The meter board contains two plug-in connectors located at the bottom center of the board, TB2 and TB3. (See Figure 1.1.1.) Connector TB2 is the input for Phase A, and TB3 is the input for Phase B.

The Class 4000/4100 meter can be used with two types of current sensors:

1. Split-core current sensor. This sensor opens so that it can be attached around the circuit being monitored without interrupting power. Unless otherwise specified, all Class 4000/4100 meters are supplied with this sensor type.
2. Solid-core current sensor. This sensor does not open and requires the monitored conductor to be removed from the circuit to install the current sensor. This type is only supplied when specified at time of order.

5.3.1 **Installing the Split-Core Current Sensor Assembly**

1. Each phase being monitored will require one two-piece current sensor assembly. Open the two-piece current sensor assembly by releasing the nylon clamp using a flathead screwdriver.



2. Reassemble the current sensor assembly around the conductor(s) to be monitored. Ensure the current sensor halves marked "Load" are both facing the load side of the conductor. The colored arrow will be on the source side of the conductor being monitored and **MUST** be pointed in a clockwise direction around the conductor being monitored. Tighten the nylon clamp to complete the assembly.

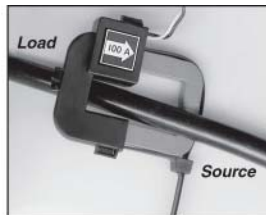

IMPORTANT: When looking from the source side of the conductor(s) being monitored, you should see the arrow on the current sensor assembly. The arrow should be pointing in a clockwise direction around the conductor(s) being monitored. If the arrow is not positioned on the source side, inaccurate readings will result.

5.3.2 Current Sensor Wiring

Once the current sensors are installed onto their appropriate phase conductors, you can begin terminating the current sensors onto the Class 4000/4100 meter board using the two-screw removable terminal plug. The current sensor leads can be extended up to 2,000 feet from the meter. To extend the length of the wires, use #22 AWG twisted-pair wire with one white and one black wire.

The current sensor connected to TB2 must be on the same phase as the MAINS voltage terminal A and the current sensor connected to TB3 must be on the same phase as the MAINS voltage terminal B. Failure to do so may result in inaccurate readings.

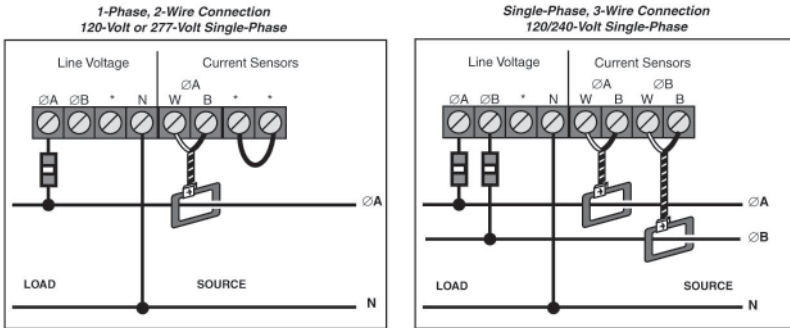

NOTE: When the E-Mon D-Mon® Class 4000/4100 meter is installed where the tenant has access to the electrical panel powering the meter, it is suggested that a dedicated breaker NOT be used to power the meter, as a dedicated breaker can be shut off and stop the meter from recording. If a dedicated breaker must be used, it should be a lockable style.

5.4 Main Power

After the meter circuit wiring has been examined for correctness, power may be applied to the circuit board. If the monitored circuit is under load, the LED in the meter's upper right hand corner will actively blink - indicating the amount of load by the frequency of its pulse. A heavy load will blink faster than a light load. Very light loads will result in an extended blink time.

6.0 Features & Operating Guide

The 6-digit display shows the kilowatt-hours consumed by the metered load.

The blinking LED indicator provides a visual pulse signal of the meter's load. A heavier load will increase the blink frequency.

* The sealing tab, which is supplied when the anti-tamper option is ordered, provides the meter with a location to install a utility type security seal.

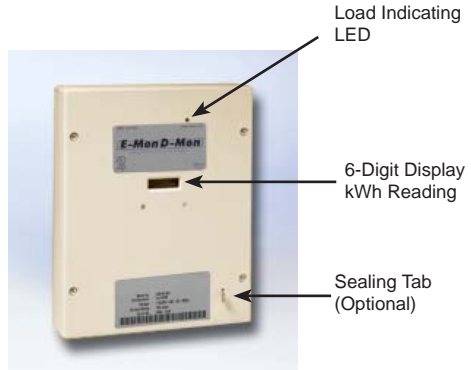

NOTE: Depending on the amount of power being used, a period of time will elapse before the meter registers. In the case of light loading, this could be as much as several hours.

6.1 **RF Wireless Metering Option (Class 4100)**

When the meter is ordered with the RF option (Class 4100), it will be provided with a factory installed 900 mHz RF module for AMR (Automatic Meter Reading.) This module is pre-wired to the meter and will be active when the meter is powered.

This module is designed to be used with E-Mon Energy software and an available RF Wireless Gateway for either on-site reading or through an internet connection. The system requires factory start-up services. Contact E-Mon for additional details.

7.0 Troubleshooting Guide

The Class 4000/4100 electronic kilowatt-hour meter is calibrated and tested at the factory before being packaged and shipped. If installed properly and in accordance with these installation instructions, the Class 4000/4100 meter will provide years of trouble-free service. If the meter should not function, the following guide will assist in troubleshooting the installation. If, after following the procedures below, the meter still does not function, please call E-Mon's technical department at (800) 334-3666 BEFORE removing the meter.

Problem

1. Display reads all ZEROs, or is not incrementing.

2. Display reads only a fraction of the power consumed.

Procedure to follow

- A. Determine if the load is sufficient to update the display (A load of less than 1% of the meter rating may require 24 hours to change the display reading.
 - B. Check the current sensor installation.
 - C. Be sure that the current & voltage inputs have proper phase relationship.
 - D. Check wiring to voltage terminals.
 - E. Check circuit breaker or fuses.
 - F. Test source for correct voltage.
-
- A. Check the supply voltage to be sure that it is on 24 hours a day.
 - B. Check the current sensors for installation and polarity.
 - C. Check the current sensor to verify that it is the correct amp rating.
 - D. Check the sensor wiring to the terminal block in the meter (verify color coding white-to-white and black-to-black.)

Important Information For The Owner

To better assist the building owner/manager, the installer should complete the following information and forward the installation manual to the building owner/manager for future reference.

Product Information

Item Installed: _____
Model Number: _____
Serial Number: _____
Date of Installation: _____

Installer Information

Installed By: _____
Company: _____
Name: _____
Phone: _____

Application Information

Purpose Of Installation: _____

Notes/Comments: _____

E-Mon, LLC
One Oxford Valley
Suite 418
Langhorne, PA 19047
(800) 334-3666
www.emon.com - info@emon.com

10/07